

# Nexia

home  
collection



2020

catalogue

home  
collection

2020

# Contents

Product	Aros	14
	Bow	19
	Mobile	24
	Tires	28
	Elegance	38
	MG_ Track	41
	Hipnos	50
	Bcn Accessories	55
Culture x light		60
Contact		64

At Nexia we provide modernity, design and well-being through technologically progressive light. We understand light as culture: its role in the creation of experiences creates a nexus between space and people. We adhere to a set of goals: products and projects that seek rigour in light, visual comfort, efficiency and innovation.

Our mission is to simplify the creation of friendly environments that connect people with technology, in order to provide unique and ultimately better experiences.

## Setting Up













ES

En Nexia aportamos modernidad, diseño y confort mediante la tecnología aplicada a la luz. Entendemos la luz como cultura: su papel en la creación de experiencias crea un nexo entre el espacio y las personas. Nos adherimos a un conjunto de objetivos: productos y proyectos que buscan el rigor lumínico, el confort visual, la eficiencia y la innovación. Nuestra misión es hacer posible la creación de entornos amables, que unan las personas y la tecnología para proporcionar experiencias únicas y memorables.

FR

Chez Nexia, nous apportons de la modernité, du design et du confort grâce à une technologie appliquée à la lumière. Nous comprenons la lumière comme une culture : son rôle dans la création d'expériences crée un lien entre l'espace et les personnes. Nous nous adhérons à un ensemble d'objectifs : des produits et des projets qui recherchent la rigueur lumineuse, le confort visuel, l'efficacité et l'innovation. Notre mission est de permettre la création d'un environnement convivial qui réunit les personnes et la technologie pour offrir des expériences uniques et mémorables.

IT

Nexia offre soluzioni moderne, di design e confortevoli grazie alla tecnologia applicabile all'illuminazione. Consideriamo la luce come Cultura: il suo ruolo nel creare esperienze contribuisce a generare un vincolo tra lo spazio e le persone che cercano efficacia, confort visivo, efficienza ed innovazione. La nostra missione è rendere possibile la realizzazione di ambienti piacevoli che uniscano le persone e la tecnologia per realizzare esperienze uniche e memorabili.

We are at a unique moment in the industry of light. Technological evolution offers opportunities in the creation of products that are more sustainable and efficient than ever before. In spite of this progress, knowledge in the use of light as a means to make our surroundings more comfortable is still lacking.

It is necessary to imbue coherence, richness and new languages into everyday products. Technology can easily seem cold, distant and alien to our perception and emotion, when in fact, the lighting industry offers light solutions increasingly adapted to our human condition. At Nexia we want to make light more accessible for people, through the study of interaction and product design, providing comfort and well-being while creating solutions that are capable of generating emotion in the everyday life. Our mission is to bring technology closer to people, and to foster the creation of comfortable environments that lead to unique moments and experiences.

Nous sommes dans un moment unique dans l'industrie de la lumière. L'évolution technologique nous offre des opportunités dans la création des produits plus durables et efficaces. Malgré ces progressions, il existe des manques dans l'usage de la lumière pour rendre les espaces plus confortables.

Il est nécessaire d'assurer la cohérence, la richesse et de nouvelles langues aux produits de tous les jours. La technologie peut facilement sembler froide, distante et étrangère à notre perception, alors qu'en réalité, le secteur de l'éclairage offre des propositions de plus en plus adaptées à notre condition. Depuis Nexia, nous voulons rapprocher la lumière aux personnes, à travers l'étude de l'interaction et de la conception des produits, en apportant du confort et du bien-être, et en créant des solutions capables de transmettre l'émotion au quotidien. Notre mission est de rapprocher la technologie aux personnes et de favoriser la création d'espaces confortables qui produisent des expériences uniques.

Nos encontramos en un momento único en la industria de la luz. La evolución tecnológica nos ofrece oportunidades en la creación de productos más sostenibles y eficientes. A pesar de estos avances, existen carencias de conocimiento en el uso de la luz para hacer los espacios más confortables.

Es necesario aportar coherencia, riqueza y lenguajes nuevos a los productos cotidianos. La tecnología puede fácilmente parecer fría, lejana y ajena a nuestra percepción, cuando en realidad, el sector de la iluminación ofrece propuestas cada vez más adaptadas a nuestra condición. Desde Nexia queremos acercar la luz a las personas, a través del estudio de la interacción y del diseño de producto, aportando confort y bienestar, y generando soluciones que sean capaces de transmitir la emoción en nuestro día a día. Nuestra misión es acercar la tecnología a las personas, y fomentar la creación de espacios confortables que produzcan experiencias únicas.

Ci troviamo in un momento unico nel settore dell'illuminazione. L'evoluzione tecnologica ci offre l'opportunità di realizzare prodotti più sostenibili ed efficienti. Nonostante questi sviluppi esiste ancora una mancanza di conoscenze nell'utilizzo della luce con lo scopo di creare spazi confortevoli.

È necessario fornire ai prodotti di uso quotidiano una nuova ricchezza e un nuovo linguaggio. La tecnologia può sembrare qualcosa di lontano e freddo, ma in realtà nell'illuminazione offre delle possibilità sempre più adatte alle nostre esigenze. In Nexia vogliamo avvicinare la luce alle persone, attraverso lo studio dell'interazione e del disegno, dando benessere e confort oltre a soluzioni capaci di trasmettere emozioni ogni giorno. La nostra missione è avvicinare la tecnologia alle persone promuovendo la creazione di spazi capaci di generare esperienze uniche.

Culture x light









# Aros

Designed to integrate design with functionality. Made of aluminium, it allows the combination of direct and indirect general lighting with accent lighting. It is a system that can be fully customized to suit each space.





Index Protection: IP20  
Driver: Included  
CRI: 80  
Temperature: 2700K / 3000K  
Lifetime: 50.000h  
Technology: LED  
Guarantee: 5 years  
Class II  
Voltage: 110-240V (31501-)  
220-240V (31512-/  
31523- / 31535-)

by  
Nahrang Design

ES

Aros ha sido diseñada para integrar diseño con funcionalidad. Fabricada de aluminio permite combinar iluminación general directa e indirecta con iluminación acentual. Es un totalmente personalizable que permite adaptarse a cada espacio.

FR

Aros a été conçu pour intégrer le design à la fonctionnalité. Fabriqué en aluminium, il est possible de combiner un éclairage général direct et indirect avec un éclairage d'accentuation. Il s'agit d'un système entièrement personnalisable qui permet de l'adapter à chaque espace.

IT

Aros è stato pensato per offrire disegno e praticità. Fabricato in alluminio permette di combinare l'illuminazione diretta e più generale ad una indiretta e d'accento. È un sistema totalmente personalizzabile che permette di adattarsi ad ogni spazio.

Aros Single  
31512-

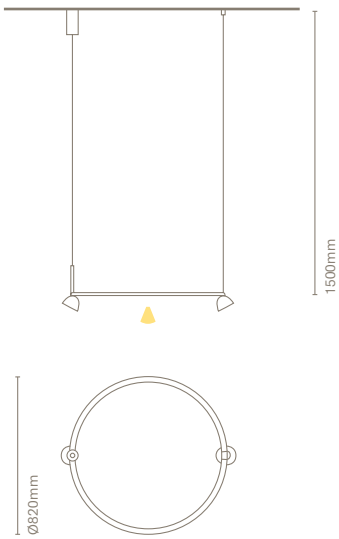

Aros Double  
31523-

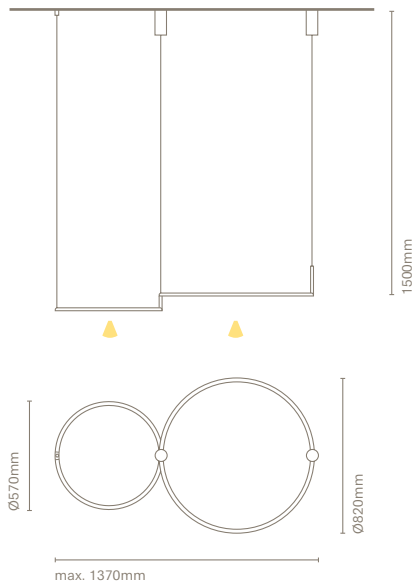

Aros Triple  
31535-

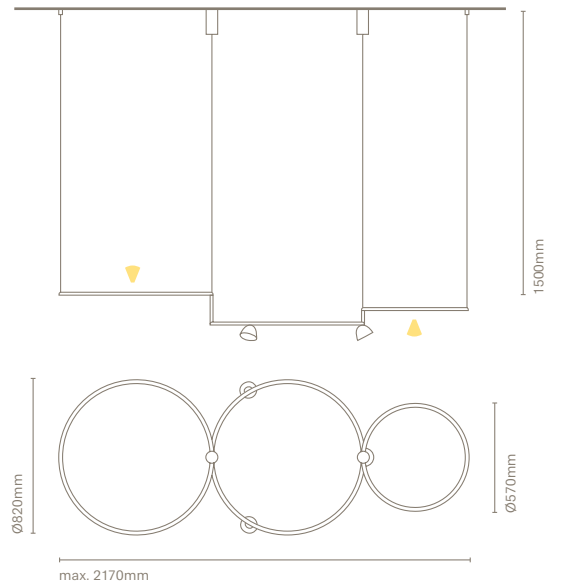

Aros Wall Lighting  
31501-

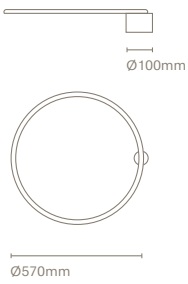

Accessory for overlaying  
Aros Wall included

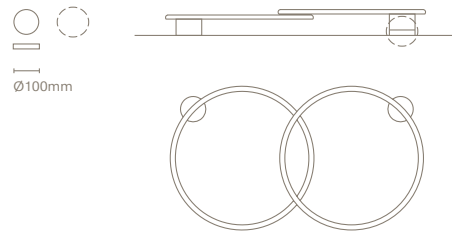

31512-	COLOUR	CRI/TEMP.	LED
1	Black	C 830	2 4090+1240/34+15W

31523-	COLOUR	CRI/TEMP.	LED
1	Black	C 830	3 6830lm/61W

31535-	COLOUR	CRI/TEMP.	LED
1	Black	C 830	3 6830+1860lm/61+22W

31501-	COLOUR	CRI/TEMP.	LED
1	Black	G 827	2 2740lm/27W
		C 830	





Created to give an incredible lighting effect thanks to the backlighting. The aesthetics of the whole family is unique, elegant and minimalistic. Its multiple versions allow you to apply this iconic effect in any space.

Bow

ES

Bow ha sido diseñado para proporcionar un increíble efecto lumínico gracias a la retroiluminación. La estética de toda la familia es única, elegante y minimalista, sus múltiples versiones te permiten aplicar este icónico efecto en cualquier espacio.

FR

Bow a été conçu pour fournir un incroyable effet grâce au rétro-éclairage. Avec une esthétique unique, élégante et minimaliste dans toute la famille, ses multiples versions vous permettent d'appliquer cet effet iconique dans n'importe quel espace.

IT

Bow è stato pensato per offrire un incredibile effetto luminoso grazie alla retroilluminazione. Un'estetica unica, elegante e minimalista. Le sue molteplici varianti ne permettono l'utilizzo in qualsiasi spazio.

Index Protection: IP20  
 Driver: Included  
 CRI: 80  
 Lifetime: 50.000h  
 Temperature: 2700K  
 Technology: LED  
 Guarantee: 5 years  
 Class II  
 Voltage: 110-240V

Bow has been selected for the ADI Awards 2020

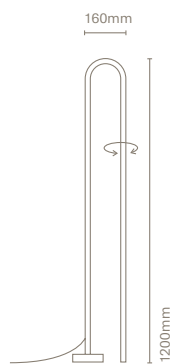

Bow Floor lamp 31115-

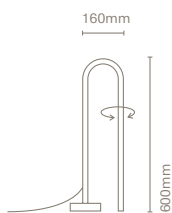

Bow Table lamp 31110-

	COLOUR	CRI/TEMP.	LED	DIMMING
31115-	1 Black	G 827	3 2880lm/22W	I Dimmer included

	COLOUR	CRI/TEMP.	LED	DIMMING
31110-	1 Black	G 827	1 1120lm/10W	I Dimmer included





Index Protection: IP20  
Driver: Included  
CRI: 80  
Lifetime: 50.000h  
Temperature: 2700K  
Technology: LED  
Guarantee: 5 years  
Class I  
Voltage: 110-240V (31130-)  
220-240V (31125-)



Bow  
Suspended H1200  
31125-

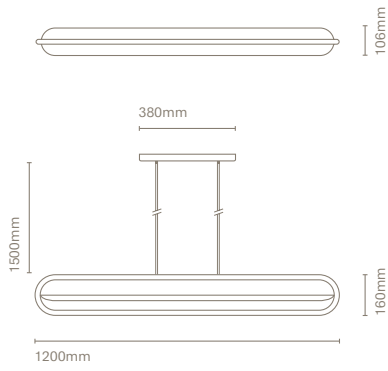

Bow  
Suspended V 650  
31130-

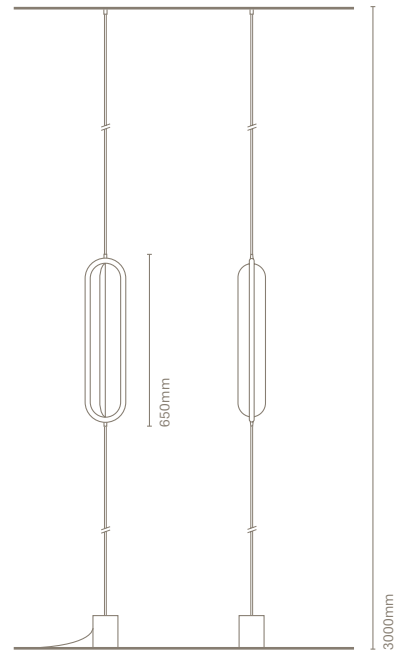

31125-

COLOUR	CRI/TEMP.	LED
1 Black	G 827	3 2370lm/21W

31130-

COLOUR	CRI/TEMP.	LED	DIMMING
1 Black	G 827	1 1000lm/10W	Dimmer included

# Mobile

Designed to get a linear and clean shape in spaces. With this fixture we achieve comfort in all senses; light and acoustic. Its customizable panels in finishes absorb sound with a sustainable sense.





Index Protection: IP20  
Voltage: 230V \*  
Driver: Included  
CRI: 80  
Lifetime: 50.000h  
Temperature: 2700K/3000K  
Technology: LED  
Guarantee: 5 years  
Class I

\* Consult for 120V

by  
Nahrang Design

ES

Mobile ha sido diseñado para conseguir un efecto lineal y limpio en los espacios. Con esta luminaria conseguimos confort en todos sus sentidos; lumínico y acústico. Sus paneles personalizables en acabados amortiguan el sonido con un sentido sostenible.

FR

Mobile a été conçu pour obtenir un effet linéaire et propre dans les espaces. Avec ce luminaire, nous atteignons le confort dans tous les sens ; lumineux et acoustique. Ses panneaux personnalisables dans les finitions amortissent le son avec un sens durable.

IT

Mobile è stato disegnato per ottenere un effetto lineare e pulito negli spazi. Otteniamo confort visivo ed acustico. I suoi pannelli fonoassorbenti sono personalizzabili e attutiscono i rumori mantenendo la sostenibilità.

Mobile 600  
31210-

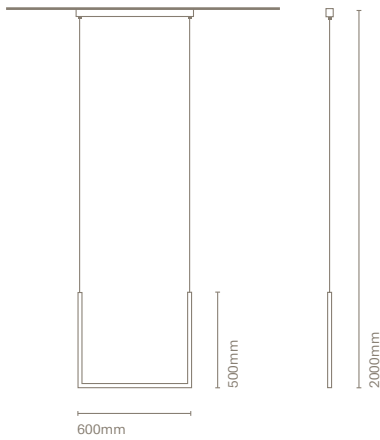

Mobile 600 acoustic  
31211-

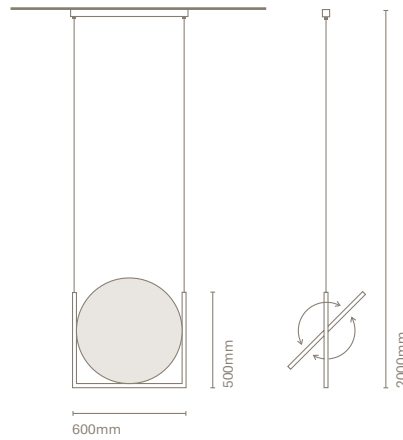

Mobile 1200  
31225-

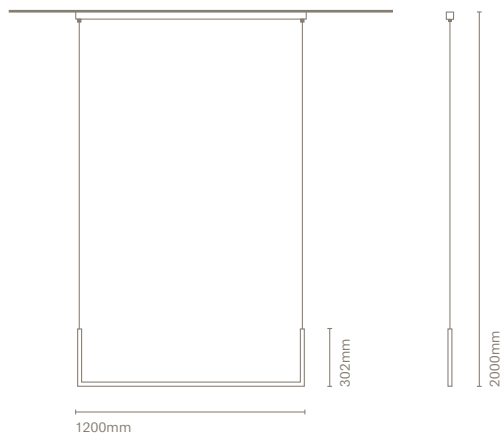

Mobile 1200 acoustic  
31226-

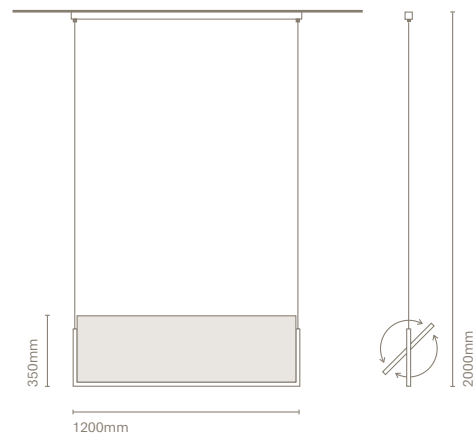

31210-

COLOUR	CRI/TEMP.	LED	DIMMING
1 Black	G 827	2 1750lm/13W	- No dimming
	C 830		D DALI

31225-

COLOUR	CRI/TEMP.	LED	DIMMING
1 Black	G 827	4 3500lm/26W	- No dimming
	C 830		D DALI

31211-

COLOUR	COLOUR ACOUSTIC	CRI/TEMP.	LED	DIMMING
1 Black	● S Silver grey	G 827	2 1750lm/13W	- No dimming
	● A Anthracite	C 830		D DALI
	● D Dark camel			
	● R Red			

31226-

COLOUR	COLOUR ACOUSTIC	CRI/TEMP.	LED	DIMMING
1 Black	● S Silver grey	G 827	4 3500lm/26W	- No dimming
	● A Anthracite	C 830		D DALI
	● D Dark camel			
	● R Red			

# Tires

The perfect balance between design, technicity and warmness. It allows your personalization by playing with the multiple finishes and shapes available. This family includes the sustainable acoustic panel to absorb the acoustic pollution of the space.







Tires Model 1  
31310-

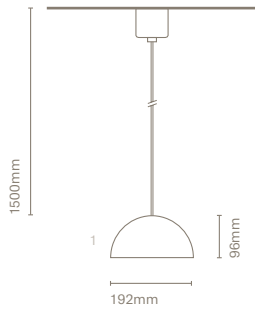

Tires Model 2  
31320-

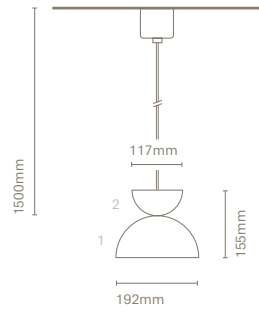

Tires Model 3  
31330-

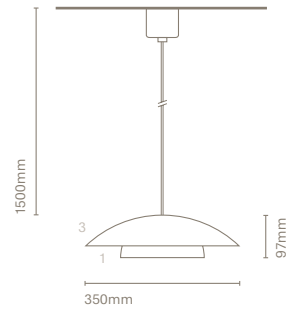

Tires Model 4  
31340-

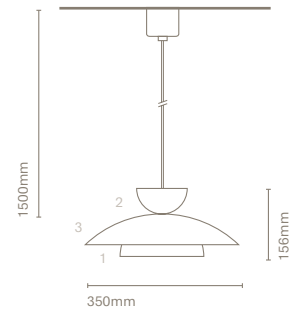

Tires Model 5 Acoustic  
31350-

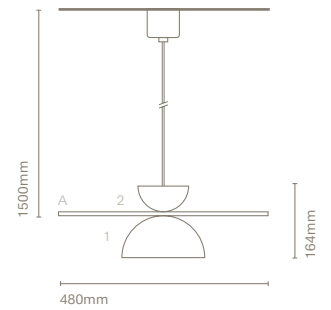

31310-

	COLOUR CUPOLA	CRI/TEMP.	LED
●	M Grey blue	H 927	1 1300lm/12W
●	J Cement grey	E 930	
●	E Silk grey		
●	S Red oxide		

31320-

	COLOUR CUPOLA 1	COLOUR CUPOLA 2	CRI/TEMP.	LED
●	M Grey blue	M Grey blue	H 927	1 1300lm/12W
●	J Cement grey	J Cement grey	E 930	
●	E Silk grey	E Silk grey		
●	S Red oxide	S Red Oxide		

31330-

	COLOUR CUPOLA 1	COLOUR CUPOLA 3	CRI/TEMP.	LED
●	M Grey blue	M Grey blue	H 927	1 1300lm/12W
●	J Cement grey	J Cement grey	E 930	
●	E Silk grey	E Silk grey		
●	S Red oxide	S Red Oxide		

31340-

	COLOUR CUPOLA 1	COLOUR CUPOLA 2	COLOUR CUPOLA 3	CRI/TEMP.	LED
●	M Grey blue	M Grey blue	M Grey blue	H 927	1 1300lm/12W
●	J Cement grey	J Cement grey	J Cement grey	E 930	
●	E Silk grey	E Silk grey	E Silk grey		
●	S Red oxide	S Red Oxide	S Red Oxide		

31350-

	COLOUR CUPOLA 1	COLOUR CUPOLA 2	COLOUR ACOUSTIC	CRI/TEMP.	LED
●	M Grey blue	M Grey blue	● S Silver grey	H 927	1 1300lm/12W
●	J Cement grey	J Cement grey	● A Anthracite	E 930	
●	E Silk grey	E Silk grey	● D Dark camel		
●	S Red oxide	S Red oxide			

ES

TIRES es la mezcla perfecta entre diseño, técnica y calidez. Permite su completa personalización jugando con los múltiples acabados y formas disponibles. Esta familia cuenta con el panel acústico eco sostenible para amortiguar la contaminación acústica del espacio.

Index Protection: IP20  
Voltage: 230V \*  
Driver: Included  
CRI: 90  
Lifetime: 50.000h  
Temperature: 2700K/3000k  
Technology: LED  
Guarantee: 5 years  
Class I

\* Consult for 120V

FR

TIRES est le mélange parfait entre le design, la technicité et la chaleur. Permet une complète personnalisation en jouant avec les multiples finitions et les formes disponibles. Cette famille compte avec un panneau acoustique écologique pour atténuer la pollution sonore dans l'espace.

IT

TIRES è un mix perfetto tra design, tecnica e prossimità. Permette una completa personalizzazione grazie alla varietà di finiture e forme disponibili. Una famiglia disponibile anche con il pannello fonoassorbente eco sostenibile per attutire i rumori ambientali.



by  
Nahrang Design

Guillem Ferran interviews Ester Pujol and Dani Vila, the product designers at the helm of Nahtrang Studio, about the lighting industry, the products the studio has developed, and Nexia's future.

Dani Vila  
& Ester Pujol

Interview by  
Guillem Ferran

Guillem: What does Nexia represent to you? What could you highlight?

Ester: To be involved in these projects has given us the chance to take part in the brand's new positioning and their new product approach.

Dani: Up until this point, Nexia had always been associated with quality of light. The company didn't focus so much on the identity of its products, but on an optimal management of light.

- |   |   |   |  |
|---|---|---|--|
| E | This made it clear that it was necessary to imbue the catalog's new products with more personality.   | D | To generate a series of objects that are warmer, more human and, ultimately, more visible in a given space.  |
| D | Nexia was sober, functional, and met – by far – the requirements that are implicit in lighting up a space, but it lacked presence.  | G | How do you think the industry is evolving?   |
| E | It also lacked interactivity and the possibility of enabling people to personalise the product. Prescribers, final users... people, in the end, are what's most important.  | E | The industry of light is increasingly at a turning point. We're getting used to seeing how companies that have a tradition in domestic or decorative lighting take a step further to realise projects that have more to do with contract and interior design. On the other hand, it's not as common to see technical companies manage to get closer to the final audience with designs that are friendly – this particular fact has made the project all the more interesting to us. |
| G | What does this new collection express?  | G | What do your proposals provide?  |
| E | A formal break from the products that were already in their catalog, and a foray into the use of new colours and materials.   | D | To humanise a product that was in itself very technical was an incentive. Our proposals have brought us closer to the end users, and we've strived to make the designs recognisable both in form and in function.  |
| D | A greater sense of identity and singularity: each of the collections we have presented strives to find balance between form and technical expertise. Nexia couldn't be understood but as a combination of both design and technology. | G | Among your different proposals, have you designed systems of luminaires?   |
| E | To not only work with the quality of light but also with the object, given that technical light control is already a defining trait of Nexia's products.  |   |  |

Daniel Vila (Sant Quirze Safaja, 1975)  
& Ester Pujol (Sabadell, 1977),  
industrial designers from Escola  
Massana (Barcelona).





- D Yes. For a company like Nexia, systems are very important as they offer configurations that can be adapted to all types of project solutions. Systems are necessary to understand, interpret and light up an entire space.
- E We've created elements with a strong presence that also manage to fit in with different environments, and provide a lot of compositional flexibility.
- G What was the process of working with Nexia like?
- D It was a very intense and stimulating process. We wanted to understand and provide an outlet for the company's concerns, and we did our best to prioritise their needs when it came to proposing concepts that we deemed interesting.
- E We had several meetings with the goal of acquiring a better understanding of the brand and its market, and to analyse in which direction other technical companies were headed in order to create a path that was unique to Nexia.
- D The connection took place very quickly, and Nexia trusted our judgement without reservations.
- E It's also worth mentioning that the job was carried out as a team from the beginning – a collaborative effort from the marketing and technical departments, and ourselves.
- D This close partnership was ultimately to thank for an outcome that we're very happy with.
- G What would you highlight about Tires?
- D Among all of our proposals, it's the most decorative one: we've simplified well known shapes that are versatile, exchangeable and make it possible to convey different emotions.
- E It combines the philosophies of both Nahtrang and Nexia, from the diffuser to the way parts are affixed... and, above all, colour: we added natural and neutral hues to a catalog that was mainly populated with white, black and silver products.
- G How did you find the archetype to create a piece that feels so familiar?
- D We've acquainted ourselves with the Nordic tradition and style, with the influence of other companies that have been out there for quite a while.
- E These are pieces that have a presence in our collective subconscious as the Nordic heritage. We've worked with proportions and relationships between basic shapes that result from the process of metal spinning.
- D The details communicate that we're in front of a simple product, where it becomes evident whether the piece is well made or not. The upper parts feature a membrane that gives them a technological touch.
- G What about Bow?
- E It's a sculptural piece that looks to destabilise the archetypal lamp, stepping away from symmetrical shapes.
- D It's meant for everyday uses where light accompanies instead of bothering the user. This product allows for both direct and indirect light.
- E It's hairline and it's meant to project as little light as possible – especially in common settings like hotel rooms, where upon entrance it's not unusual to find oneself bothered by light instead of feeling welcomed by it.
- D Keeping in mind such situations, where people prefer to have a relaxed and intimate moment, we first came up with the light and subsequently moved on to the physical element that had to sustain it.
- E We also tried to open up new routes by working with common elements that provide a lot of flexibility: to move and adjust the light according to the needs of each person.
- G Aros makes it possible to combine direct and indirect light; general and accent light. What characterises Aros?
- D It's a direct consequence of breaking away from extruded square sections, the 90-degree linearity we've seen in previous catalogs. We've looked for something very basic that combines direct, reflected and focused light in a single element.
- E It breaks away from the reticular and modular language they're used to.
- D With Aros, we can set up spaces in ways

- that aren't as rational: constellations hanging from the ceiling, in a disorganised yet controlled way.
- E It's a dynamic and customisable luminaire – an element with many possibilities when it comes to variation, growth and simplification.
- D It enables the projection of light toward the user or the ceiling, and it has features that make it easier to light up versatile spaces. It's a product that lends itself to the creation of various points of interest.
- G What makes Mobile special?
- D Mobile stems from the need of combining acoustics with a language that is unique to Nexia.
- E It's very rational in the combination of the acoustic panel with the light: the dual function of lighting and softening a space's acoustics.
- D In a way that's visually pleasant, too: the combination of materials can be very gratifying when done with a degree of coherence.
- G Is it actually a movable luminaire?
- E The panel can be adjusted and is very versatile indoors, either by placing lamps in a row or by playing with rhythm. In the design of this type of projects, the effort goes towards imagining the product working well in isolation but also as part of a group, opening up possibilities for any interior design project.
- D It kind of looks like a swing. It's a multifaceted piece.
- G How do you see Nexia evolving in the coming years?
- E The company sits at the beginning of a path that leads to endless destinations. There's a lot to explore in the ways in which technology gets implemented in the industry of light.
- D If they keep up with their performance in the knowledge of light, they'll do very interesting projects. Nexia has taken a major qualitative leap in a short time: it's a company that is committed to innovation amid a myriad companies that aren't willing to step out of their comfort zone.
- E They've been aware of the need to step up in order not to fall behind, and continue to develop products that have identity and personality.
- G A different and dynamic collection proposal that will surely bring poetics and versatility to countless spaces.



We have created Elegance to create a feeling of warmth and comfort in ambient lighting. Made of metal steel it allows us any type of installation (up to 10m long). It is a product that allows creativity in all its elements.

Elegance



ES

Hemos creado ELEGANCE para generar sensación de calidez y confort en la iluminación de ambiente. Fabricado de metal nos permite cualquier tipo instalación (hasta 10m de largo). Es un producto que permite creatividad en su máxima esencial.

FR

Nous avons conçu ELEGANCE pour créer une sensation de chaleur et de confort dans l'éclairage d'ambiance. Fabriqué en aluminium, pour tout type d'installation (jusqu'à 10m de long). Un produit qui permet la créativité à son meilleur essentiel.

IT

Abbiamo creato ELEGANCE per realizzare ambienti familiari e confortevoli. Fabricato in alluminio permette qualsiasi tipo d'installazione (fino a 10m di lunghezza) è un prodotto che permette esprimere creatività alla sua massima potenza.

Index Protection: IP65 / IP66  
 Voltage: 230V / 24V  
 Driver: Included  
 CRI: 80/90  
 Lifetime: 30.000h / 40.000h  
 Temperature: 2700K / 3000K / 4000K  
 Technology: LED  
 Guarantee: 3 years / 5 years  
 Class II

230V set  
 21501-

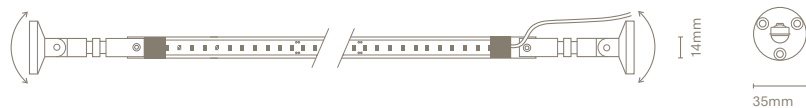

24V set  
 21505-

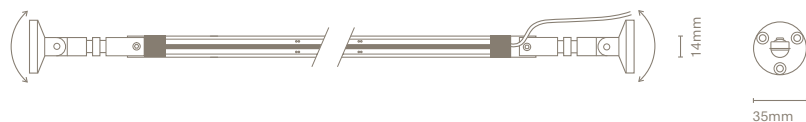

21501-	CRI/TEMP.	ANGLE	LED	LENGTH
G 827	9	120°	1 1425lm/15W/120LEDS	10 10 meters
C 830				6 6 meters
N 840				3 3 meters

21505-	CRI/TEMP.	ANGLE	LED	LENGTH
H 927	9	120°	0 990lm/11W/COB	5 5 meters
E 930				3 3 meters
H 940				



A combination of linear structures using magnetism. Thanks to its multiple accessories, it allows us to combine technical and decorative lighting in the same space. Its minimalistic aesthetics and small dimensions allow us to incorporate linear solutions in any kind of project.

## MG\_Track



ES

MG\_Track es una combinación de estructuras lineales con magnetismo. Gracias a sus múltiples accesorios nos permite combinar iluminación técnica y decorativa en un mismo espacio. Su estética minimalista y de dimensiones reducidas nos permite incorporar la solución lineal en cualquier espacio.

Index Protection: IP20  
 Voltage: 48V  
 Driver: Included  
 CRI: 90  
 Lifetime: 50.000h  
 Temperature: 2700K/3000K  
 Technology: LED  
 Guarantee: 5 years  
 Class III

FR

MG\_Track est une combinaison de structures linéaires avec magnétisme. Grâce à ses multiples accessoires, il nous permet de combiner l'éclairage technique et décoratif dans un même espace. Son esthétique minimaliste et ses petites dimensions nous permettent d'incorporer la solution linéaire dans tout espace.

IT

MG\_Track è una combinazione di una struttura lineare e magnetismo. Grazie ai suoi numerosi accessori ci permette unire l'illuminazione tecnica con quella decorativa. Un'estetica minimalista dalle dimensioni ridotte che permette incorporare una soluzione lineare in qualsiasi spazio.

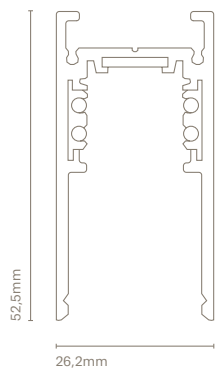

Surface mounted  
magnetic track

25901-1	Magnetic surface mounted	15A	100 cm	Black
25902-1	Magnetic surface mounted	15A	200 cm	Black
25903-1	Magnetic surface mounted	15A	300 cm	Black
25951-	Suspension Kit			
25952-	Joint			
25953-	"L" connector not electrified			

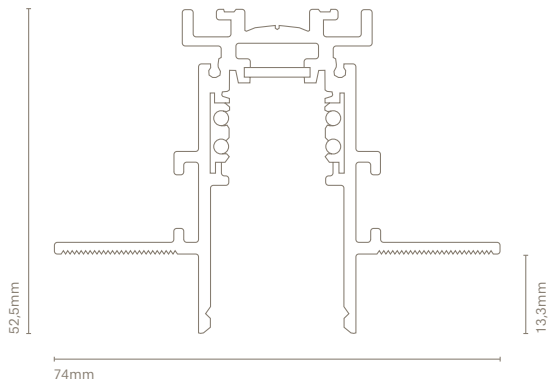

Trimless embedded  
magnetic track

25911-1	Embedded magnetic track	15A	100 cm	Black
25912-1	Embedded magnetic track	15A	200 cm	Black
25913-1	Embedded magnetic track	15A	300 cm	Black
25954-	Joint			



El nuevo carril magnético ofrece una enorme versatilidad. Te permite diseñar líneas, en ángulo recto y cambios de plano en las esquinas a 90°. Con este sistema, puedes instalar sistemas módulos de luz, luminarias suspendidas o los proyectores, combinando la iluminación de acento con iluminación general cuando sea necesario. Su sistema de instalación manual y sin herramientas es muy funcional y simple.





Common accessories

25955-	End cap with hole
25956-	End cap without hole
25957-	Power supply
25958-	Electrified lineal joint
25959-	Electrified "L" joint
25960-	Electrified flexible joint
25961-	Electrical contact cutting tool
25962-	Bluetooth (Casambi) adapter

48V Converters

25990-	Converter 110-240V	75W	48V	IP00
25991-	Converter 110-240V	150W	48V	IP00
25992-	Converter 220-240V	100W	48V	IP20
25993-	Converter 220-240V	250W	48V	IP20
25994-	Converter 110-277V	240W	48V	IP67
25995-	Converter 110-277V	320W	48V	IP67
25999-	Optocoupler for Dali *			

\* Required for Dali signal on track systems.



The new track system offers a huge versatility. It allows you to draw lines, right angle turns and plane changes in corners at 90°. With this system, you may install diffuse light modules, suspended lighting fixtures or spotlights, combine accent lighting with longitudinal general lighting where required. Its manual and tool-less installation system is highly functional and simple.



Magnetic BCN 30  
25222-

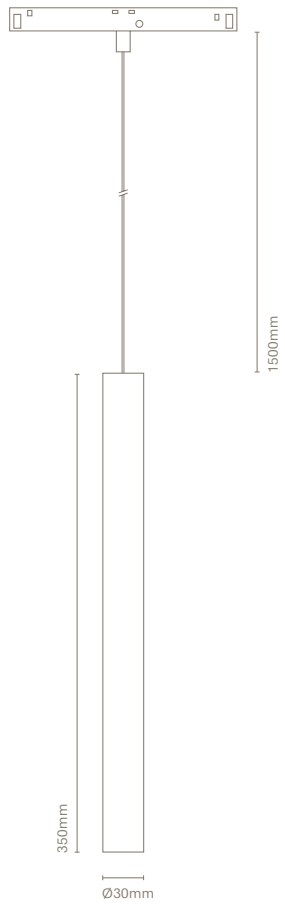

Suspended magnetic ball  
25211-

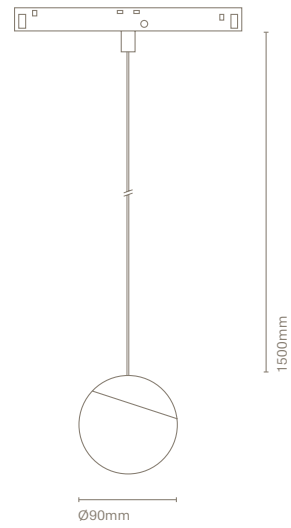

Surfaced magnetic ball  
25212-

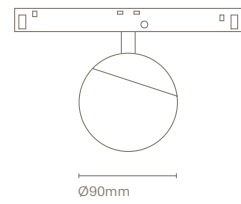

25222-

	COLOUR	CRI/TEMP.	ANGLE	LED	DIMMING
1	Black	E 930	2 25°	0 600 lm/6W	- No dimming
					D DALI

25212- /  
25211-

	COLOUR	CRI/TEMP.	ANGLE	LED	DIMMING
1	Black	H 927	9 120°	0 320lm/4W	- No dimming
		E 930			D DALI

Magnetic opal lineal  
25111-



Magnetic dot lineal  
25121-

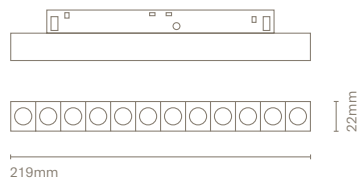

25111-

	COLOUR	CRI/TEMP.	ANGLE	LED	DIMMING
1	Black	H 927	9 120°	0 326lm/6W	- No dimming
		E 930			D DALI

25121-

	COLOUR	CRI/TEMP.	ANGLE	LED	DIMMING
1	Black	H 927	2 24°	0 904lm/15W	- No dimming
		E 930	3 36°		D DALI

Zoom spotlight 7.7W  
25011-

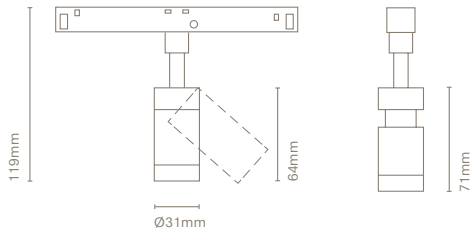

⊕ ZOOM

Eye Magnetic  
25031-

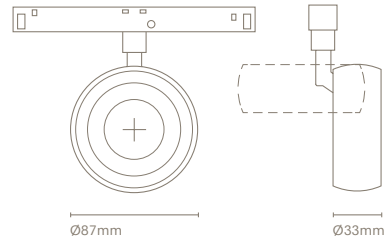

Zoom spotlight 15W  
25022-

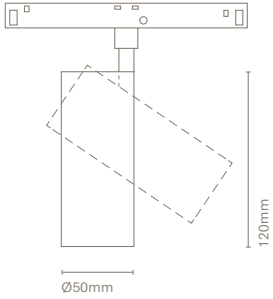

25011-

COLOUR	CRI/TEMP.	ANGLE	LED	DIMMING
1 Black	H 927	Z 10-40°	0 550lm/7,7W	- No dimming
	E 930			D DALI

25022-

COLOUR	CRI/TEMP.	ANGLE	LED	DIMMING
1 Black	G 827	1 15°	0 1025lm/15W	- No dimming
	C 830	2 24°		D DALI
		3 36°		

25031-

COLOUR	CRI/TEMP.	ANGLE	LED	DIMMING
1 Black	H 927	1 15°	2 1500lm/12,5W	- No dimming
	E 930	3 36°		D DALI

# Hipnos

Our ideal bed head is minimalistic but full of amazing details. The front plate is designed with different finishes to perfectly integrate with the interior design of each space. The fixture has a wireless charging base and a USB adapter so you never run out of battery!



ES

Nuestro cabezal de cama ideal es minimalista pero está lleno de detalles asombrosos. La placa frontal está diseñada con diferentes acabados para su perfecta integración con el interiorismo de cada espacio. ¡¡La luminaria cuenta con una base de carga inalámbrica y un adaptador USB para que nunca te quedes sin batería!!

FR

Notre tête de lit idéale est minimaliste mais pleine de détails incroyables. La plaque frontale est conçue avec différentes finitions pour une parfaite intégration avec le design intérieur de chaque espace. Le luminaire comprend une base de charge sans fil et un adaptateur USB pour ne manquer jamais de batterie !!

IT

La nostra soluzione per la testata letto è minimalista però ricca di dettagli. La parte frontale può essere personalizzata con accessori e finiture per la perfetta integrazione con lo spazio circostante. Dispone di caricabatterie wireless and una entrata USB per restare sempre collegato.

Index Protection:	IP20
Voltage:	110–240V
Driver:	Included
CRI	80
Lifetime:	50.000h
Temperature	2700K
Technology:	LED
Guarantee:	5 years
Class I	

Hipnos  
23101-

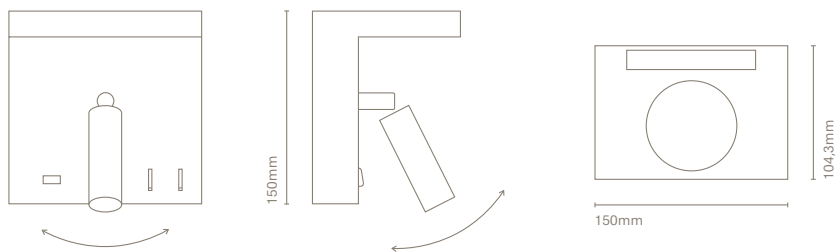

Accessory pantalla  
23109-

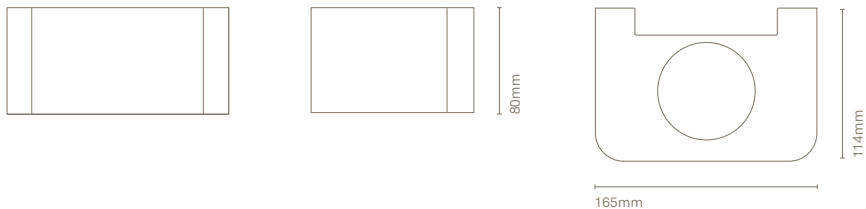

Hipnos with accessory

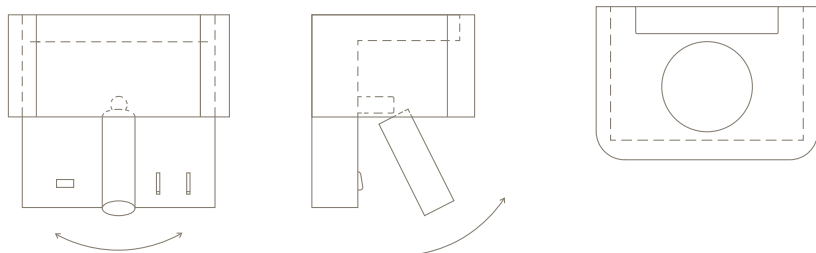



23101-

	COLOUR	CRI/TEMP.	ANGLE	LED
0	White	G 827	1 30°	0 150lm+310lm/10W
1	Black			

23109-

	COLOUR
0	White
1	Black
D	Gold
M	Wood



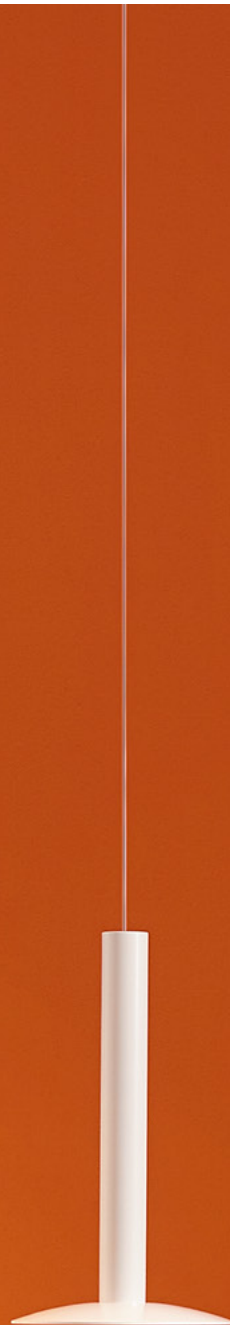
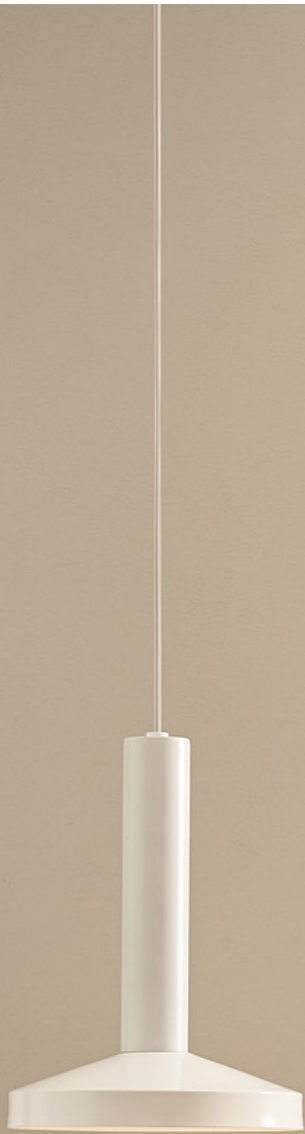

We have designed the new accessories for our BCN 30 and BCN 50 Air. These models allow us to mix the concept of technical and decorative lighting. Their clean design allows us to combine the different sizes and finishes.

## BCN Accessories

Index Protection: IP20  
 Voltage: 230V  
 Driver: Included  
 Lifetime: 50.000h  
 Technology: LED  
 Guarantee: 5 years  
 BCN 30 Class II  
 BCN 50 Class I

BCN 30 Air  
 Driver inside  
 false ceiling

06741-	Air 250 mm
06742-	Air 350 mm
06743-	Air 450 mm

COLOUR	CRI/TEMP.	ANGLE	LED	DIMMING
0 White	E 930	2 25°	0 660lm/6W	D DALI
1 Black				
A Copper				
D Gold				
G Graphite				

BCN 30 Air Canopy  
 Driver inside canopy

06751-	Air 250 mm
06752-	Air 350 mm
06753-	Air 450 mm

COLOUR	CRI/TEMP.	ANGLE	LED
0 White	E 930	2 25°	0 660lm/6W
1 Black			
A Copper			
D Gold			
G Graphite			

BCN 50 Air

06701-	BCN 50 Air L180
06702-	BCN 50 Air L260
06703-	BCN 50 Air L340

COLOUR	CRI/TEMP.	ANGLE	LED	DIMMING
0 White	H 927	2 20°	0 760lm/6W	R Edge Cut
1 Black	E 930	4 40°	1 1030lm/9W	
2 Grey	F 940	6 60°		
A Copper				
D Gold				
G Graphite				

BCN 30 Air  
 06741-  
 06742-  
 06743-

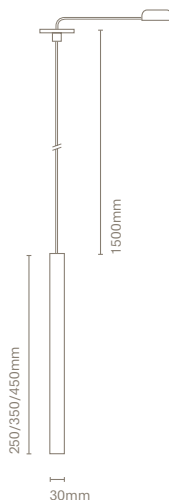

BCN 30 Air Canopy  
 06751-  
 06752-  
 06753-

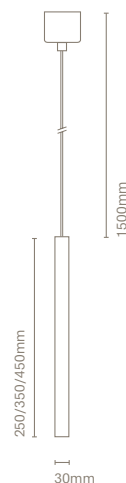

BCN 50 Air  
 06701-  
 06702-  
 06703-

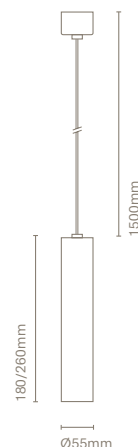

BCN 30 Air Canopy  
 + 06798-

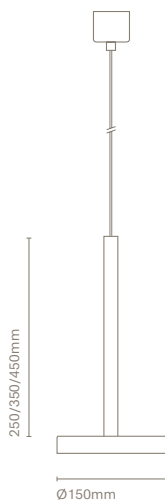

BCN 50 Air  
 + 06799-

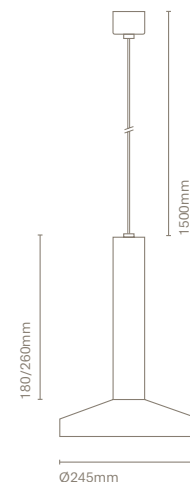

ES

Hemos diseñado los nuevos accesorios para nuestras luminarias suspendidas BCN 30 y BCN 50. Estos modelos nos permiten mezclar el concepto de iluminación técnica y decorativa. Su estilo minimalista y limpio permite combinar los diferentes tamaños y acabados.

FR

Nous avons conçu les nouveaux accessoires pour nos luminaires suspendus BCN 30 et BCN 50. Ces modèles nous permettent de mélanger le concept d'éclairage technique et décoratif. Son style minimaliste et épuré permet de combiner des différentes tailles et finitions.

IT

Abbiamo realizzato i nuovi accessori per la nostra lampana BCN 30 e BCN50. Ci permettono ottenere un mix perfetto tra una soluzione tecnica e una decorativa. Uno stile minimalista che permette combinare differenti misure e finiture

06797-

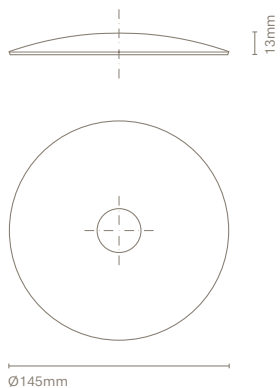

06798-

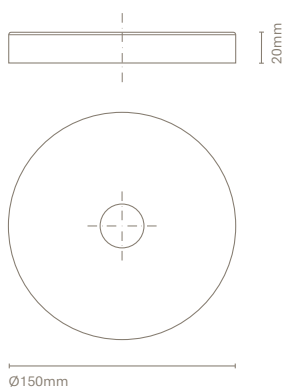

06799-

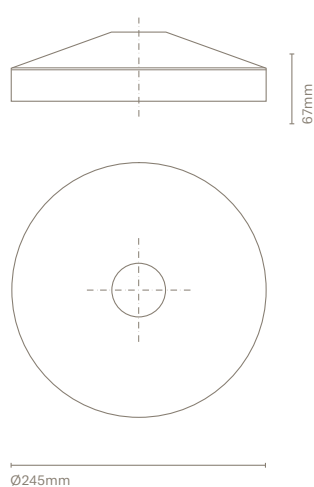

New Accesories

06797-	Structure for BCN30 Air
06798-	Structure for BCN30 Air
06799-	Structure for BCN50 Air

COLOUR

- 0 White
- 1 Black
- 2 Grey
- A Copper
- D Gold
- G Graphite

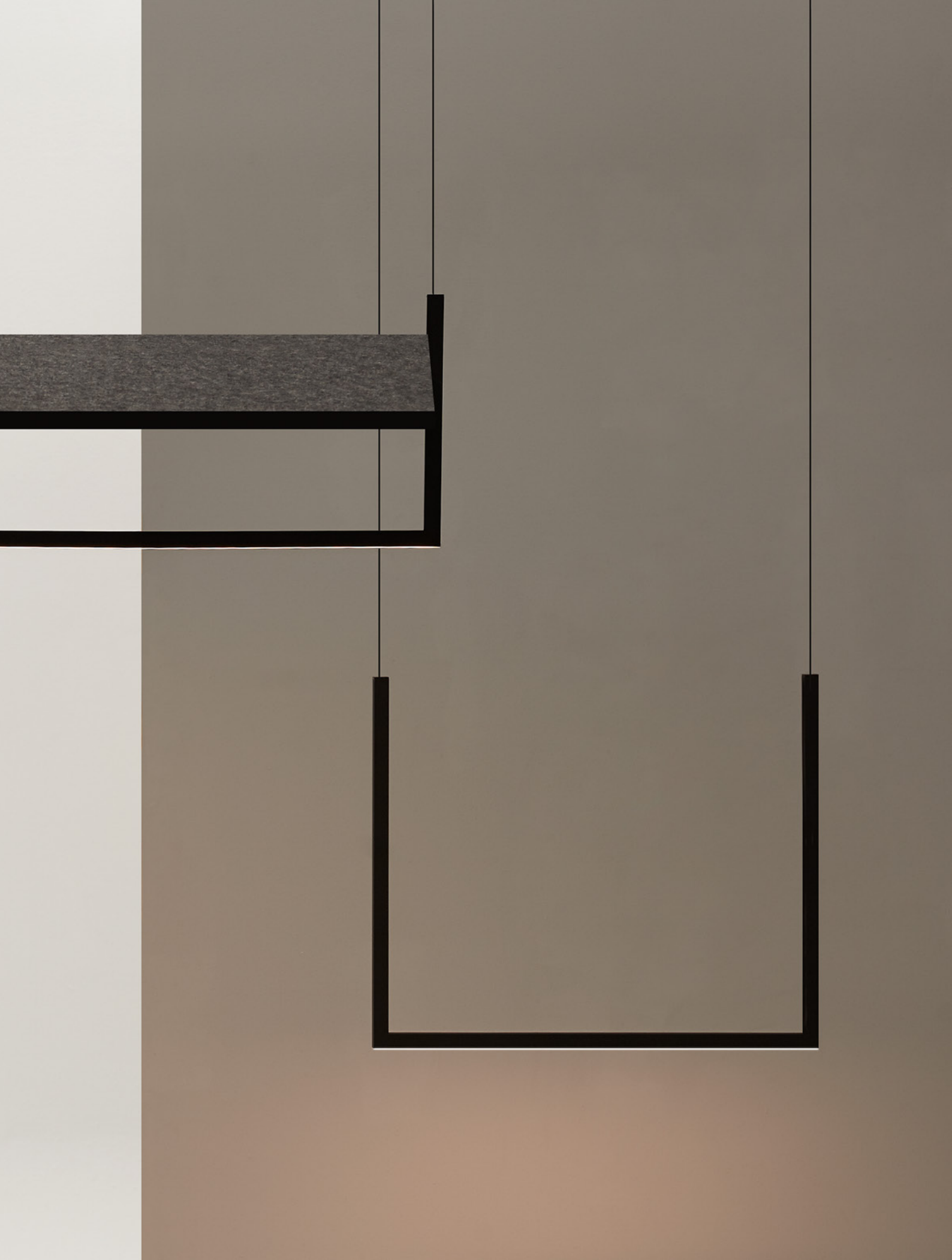





# The search of comfort in LED technology

Throughout the day we are exposed to a large amount of stimuli. Many of them are imperceptible and get routinely processed, while others build up and take a toll on our well-being. In this landscape, Nexia's contribution is about creating innovative products that are true to their function and lend themselves to pleasant contemplation.

Light works in wondrous ways – it's an intangible phenomenon that affects the way we live. It produces large quantities of serotonin and melatonin, just as it connects us to space, enabling us to find orientation and to determine whether an environment is suitable for us or not. Light is hard to understand for most, but it is in fact governed by scientific rules which at present we can control, measure and quantify. At Nexia, we work to transfer to our customers our expertise in the many positive effects that a good light grants. We want to contribute more in the creation of versatile, inclusive and friendly environments.

In this context, we're introducing changes in the way we present ourselves, we remain the same and continue to work with the degree of professionalism that has always characterised us, but are constantly working to improve our communication. We maintain our knowledge and precision, working in closer proximity with our audience, and aspiring to build closer and more fruitful relationships with our customers.

This edition of our catalog presents luminaires for indoor, outdoor and architectural applications. We're introducing new signature designs that strive to make the most of light in innovative ways without compromising their quality, strength and rigour. Our present collection incorporates new products that are designed with the users at heart, and beyond the practical aspects, we have decided to take a step further into new horizons and develop objects with greater attention to detail. We share our experience and work with new collaborators so that the knowledge of light becomes a constant in the creation of new quality products. At Nexia we ultimately seek to convey a clear and direct message: the importance of light, and its impact on our daily lives. Nexia is not only light of exceptional quality and rigour, but also design, technology and quality of life.

A lo largo del día estamos expuestos a una gran cantidad de estímulos. Muchos de ellos son imperceptibles y se procesan de manera rutinaria, mientras que otros se acumulan y afectan a nuestro bienestar. En este contexto, la contribución de Nexia se basa en crear productos innovadores que sean fieles a su función y que al mismo tiempo generen un entorno agradable.

La luz funciona de manera maravillosa: es un fenómeno intangible que afecta la forma en que vivimos. Produce grandes cantidades de serotonina y melatonina, al mismo tiempo que nos conecta con el espacio, lo que nos permite encontrar orientación y determinar si un entorno es adecuado para nosotros o no. La luz es difícil de entender para la mayoría, pero de hecho se rige por una serie de reglas científicas, que actualmente podemos controlar, medir y cuantificar. En Nexia, queremos ofrecer a nuestros clientes nuestra experiencia en los muchos efectos positivos que concede una buena luz. Queremos contribuir más en la creación de entornos versátiles, inclusivos y amigables.

En este contexto, estamos introduciendo cambios en la forma en que nos presentamos, seguimos siendo los mismos y seguimos trabajando con el grado de profesionalismo que siempre nos ha caracterizado, pero estamos trabajando incesantemente para mejorar nuestra comunicación. Mantenemos nuestro conocimiento y precisión, trabajando más cerca de nuestra audiencia, y aspirando a construir relaciones más cercanas y fructíferas con nuestros clientes.

Esta edición de nuestro catálogo presenta luminarias para aplicaciones interiores, exteriores y arquitectónicas. Estamos presentando nuevos diseños exclusivos que se esfuerzan por aprovechar al máximo la luz de formas innovadoras sin comprometer su calidad, resistencia y rigor. Nuestra colección actual incorpora nuevos productos que han sido diseñados teniendo en cuenta nuestra experiencia de usuario, y más allá de los aspectos prácticos, hemos querido dar un paso más en nuevos horizontes y desarrollar objetos con mayor atención al detalle. Compartimos nuestra experiencia y trabajamos con nuevos colaboradores para que el conocimiento de la luz se convierta en una constante en la creación de nuevos productos de calidad. En Nexia, buscamos transmitir un mensaje claro y directo: la importancia de la luz y su impacto en nuestra vida diaria. Nexia no es solo luz de calidad y rigor excepcional, sino también diseño, tecnología y calidad de vida.

Tout au long de la journée, nous sommes exposés à un grand nombre de stimulations. Beaucoup d'entre eux sont imperceptibles et sont traités régulièrement, tandis que d'autres s'accumulent et s'impose dans notre bien-être. Dans ce contexte, la contribution de Nexia se base sur la création de produits innovants fidèles à leur fonction et en même temps créant un environnement agréable.

Une lumière fonctionne à merveille : c'est un phénomène intangible qui a beaucoup à voir dans notre façon de vivre. Un grand nombre de sérotonine et de mélatonine se produit, tout en nous connectant dans l'espace, nous permettant de trouver une direction et de déterminer si un environnement nous convient ou pas. La lumière est difficile à comprendre pour la plupart des gens, mais elle est en fait régie par une série de règles scientifiques que nous pouvons actuellement contrôler, mesurer et quantifier. Chez Nexia, nous voulons offrir à nos clients notre expérience dans les nombreux effets positifs qu'une bonne lumière nous fournit. Nous voulons contribuer davantage à la création d'environnements polyvalents, inclusifs et conviviaux.

Dans ce contexte, nous introduisons des changements dans notre façon de nous présenter, nous restons les mêmes et nous continuons à travailler avec le degré de professionnalisme qui nous a toujours caractérisé, mais nous travaillons sans relâche pour améliorer notre communication. Nous conservons nos connaissances et notre précision, en travaillant plus près de notre public et en établissant des relations plus étroites et plus fructueuses avec nos clients.

Cette édition de notre catalogue présente des luminaires pour des applications intérieures, extérieures et architecturales. Nous introduisons des nouveaux designs exclusifs qui s'efforcent de profiter au maximum la lumière de manière innovante sans engager la qualité, la résistance et la rigueur. Notre collection actuelle comprend des nouveaux produits qui ont été conçus tenant compte notre expérience comme utilisateur, et au-delà de la praticité, nous voulons aller plus loin dans des nouveaux horizons et développer des objets en faisant plus d'attention aux détails. Nous partageons notre expérience et travaillons avec des nouveaux collaborateurs afin que la connaissance de la lumière devienne une constante dans la création de nouveaux produits de qualité. Chez Nexia, nous cherchons transmettre un message clair et direct : l'importance de la lumière et son impact sur notre vie quotidienne. Nexia n'est pas seulement une lumière d'une qualité et d'une rigueur exceptionnelles, mais aussi un design, une technologie et une qualité de vie.

Durante tutto il giorno siamo esposti a una grande quantità di stimoli. Molti di essi sono impercettibili mentre altri influenzano il nostro benessere. Il contributo di Nexia si manifesta nel creare prodotti innovativi, fedeli alla loro funzionalità, ma capaci di creare un ambiente gradevole.

La luce funziona in modo meraviglioso: è un aspetto intangibile che influenza la nostra vita. Produce serotonina e melatonina oltre a collegarci con lo spazio, permettendoci di orientarci e decidere se un ambiente è adeguato o no. La luce è difficile da capire, si basa su una serie di regole scientifiche che oggi si possono controllare, misurare e quantificare. In Nexia vogliamo offrire ai nostri clienti la nostra esperienza e gli effetti positivi che offre la luce. Vogliamo collaborare alla creazione di spazi versatili e amichevoli.

Per questo stiamo introducendo cambi nel modo di presentarci, lavorando incessantemente nella comunicazione senza tralasciare la professionalità che da sempre ci ha contraddistinto. Manteniamo la nostra conoscenza e precisione lavorando vicino a voi e aspirando a relazioni di vicinanza.

Questo catalogo presenta lampade per interni, esterni e architeturali. Stiamo presentando nuovi disegni che approfittano al massimo la luce in forme innovatrici capaci di non compromettere la qualità, la resistenza e il rigore. Questa collezione include soluzioni che hanno considerato la nostra esperienza con i clienti oltre ad aspetti pratici ed è frutto di nuove collaborazioni capaci di creare lampade di qualità ed elevata personalizzazione. In Nexia cerchiamo di trasmettere un messaggio in modo forte e chiaro: L'importanza della luce e del suo impatto sulla nostra vita. Nexia non è solo luce di qualità e rigore, ma anche design, tecnologia e qualità di vita.



Graphic Design  
& Art Direction:  
Affaire

Text:  
Guillem Ferran,  
Pol Pérez & Gina Olivé

Creative Direction:  
Josep Román Barri

Printed & bound:  
Agpograf, 2019

Photography:  
Geray Mena

Thanks to:  
Raquel Piteira, Lluís Torres,  
Fede Garriga, Jose Lorem  
Dani Vila, Ester Pujol

Set Design:  
María Sobrino

Stylist:  
Adela Rodríguez

Prop-Styling:  
María Ona

Post-Production:  
Studio Wolfram (Campaign)  
Rubén Chase

Illustration:  
Pol Montserrat

Nahtrang photography:  
Cosmic, by Josep Casanova